

UPA-1P Compact Wide Coverage Loudspeaker

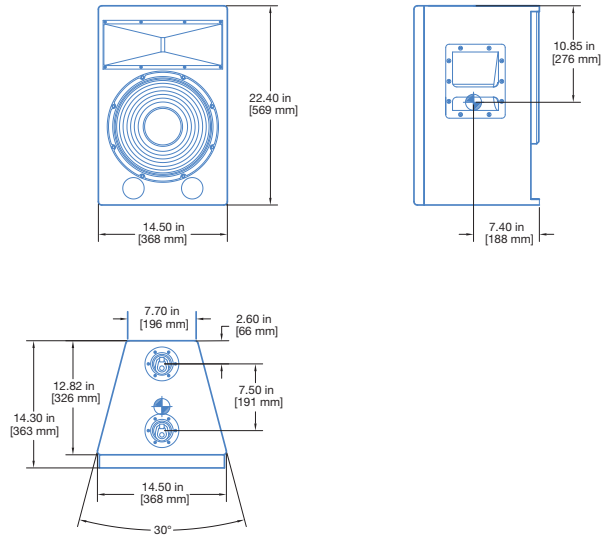

The UPA-1P loudspeaker provides high power output, low distortion, and consistent polar response in a compact, vented two-way enclosure. The loudspeaker features a 12-inch cone low-frequency driver and a 3-inch diaphragm compression driver coupled with a 100° horizontal by 40° vertical constant-Q horn. The versatile UPA-1P has a variety of sound reinforcement applications including as a main front-of-house loudspeaker in small- to mid-sized venues and as a fill loudspeaker in larger systems.

The extraordinarily smooth and predictable behavior of its proprietary high-frequency horn distinguishes the UPA-1P. The result of intensive research in Meyer Sound's anechoic chamber, the patented UPA-1P horn design exhibits constant Q. The beamwidth remains consistent within close tolerances, in both the horizontal and vertical planes and across the horn's operating frequency range of 1200 Hz to 18 kHz. The result is uniform attenuation of all frequencies outside the specified beamwidth with minimal side lobing. Uniformly predictable polar behavior takes much of the guesswork out of system design and ensures arrays that exhibit minimal destructive interference.

A proprietary two-channel, class AB/bridged power amplifier with complementary MOSFET output stages drives the UPA-1P. Total peak power output is 1000 watts; audio is processed through an electronic crossover and correction filters for phase and frequency response, as

well as driver protection circuitry. Phase-corrected electronics ensure flat acoustical amplitude and phase response, resulting in exceptional impulse response and precise imaging.

The field-replaceable amplifier/processing package incorporates Meyer Sound's Intelligent AC™, which auto-selects the correct operating voltage, suppresses high voltage transients, filters EMI and provides soft-start power-up. The high common-mode rejection of the laser-trimmed differential input circuit permits long signal runs through a simple shielded twisted-pair cable. The UPA-1P cabinet provides XLR input and looping output connectors for balanced audio and a powerCON20 connector for power. The optional RMS™ remote monitoring system module provides comprehensive monitoring of loudspeaker parameters from a host computer running Compass® software.

Meyer Sound covers the durable trapezoidal enclosure with a slightly textured black finish and includes a protective powder-coated, hex-stamped steel grille with a black mesh. Standard rigging points are four ring and stud pan fittings (two each, top and bottom) with load rating of 420 lb (190.51 kg) at a 5:1 safety factor. Adjustable yokes and pole mount adapters are available. Options include weather protection and custom color finishes for applications requiring specific cosmetics.

FEATURES AND BENEFITS

- Exceptional fidelity, power capability and extended high-frequency performance
- Extraordinarily flat amplitude and phase response for tonal accuracy and precise imaging
- Constant-Q horn affords uniform response throughout the coverage area
- Predictable array performance ensures system design flexibility
- Surprising power capability in a compact package

APPLICATIONS

- Concert halls, clubs, houses of worship
- Theatrical sound reinforcement
- Portable and installed audio-visual systems
- Cinema surround sound and effects
- Compact voice reinforcement systems
- Frontfill and under balcony

SPECIFICATIONS

ACOUSTICAL ¹	
Operating Frequency Range ²	60 Hz - 18 kHz
Frequency Response ³	80 Hz - 17 kHz \pm 4 dB
Phase Response	600 Hz - 16 kHz \pm 35°
Linear Peak SPL ⁴	130.5 dB with crest factor >14 dB (M-noise), 128 dB (Pink noise), 131.5 dB (B-noise)
COVERAGE	
Horizontal Coverage	100°
Vertical Coverage	40°
TRANSDUCERS	
Low Frequency	One 12-inch cone driver; 2 Ω nominal impedance
High Frequency	One 3-inch compression driver; 16 Ω nominal impedance
AUDIO INPUT	
Type	Differential, electronically balanced
Maximum Common Mode Range	\pm 15 V DC, clamped to earth for voltage transient protection
Connectors ⁵	XLR 3 female input with male loop output; optional XLR 5-pin connectors to accommodate both balanced audio and RMS signals.
Input Impedance	10 k Ω differential between pins 2 and 3
Wiring	Pin 1: Chassis/earth through 220 k Ω , 1000 pF, 15 V clamp network to provide virtual ground lift at audio frequencies Pin 2: Signal + Pin 3: Signal - (optional polarity reversal switch) Pin 4: RMS Pin 5: RMS Case: Earth ground and chassis
Nominal Input Sensitivity	0 dBV (1.0 V rms) continuous is typically the onset of limiting for noise and music
Input Level	Audio source must be capable of producing of +20 dBV (10 V rms) into 600 Ω to produce the maximum peak SPL over the operating bandwidth of the loudspeaker.
AMPLIFIER	
Type	Two-channel complementary MOSFET output stages (class AB/bridged)
Total Output Power ⁶	1000 W peak
THD, IM, TIM	< 0.02%
Cooling	Convection; 24 V DC output for optional external fan
AC POWER	
Connector	PowerCON20 input
Automatic Voltage Selection	90–265 V AC
Safety Rated Voltage Range	100–240 V AC, 50–60 Hz
Turn-on and Turn-off Points	90 V AC turn-on, no turn-off; internal fuse-protection above 265 V AC
CURRENT DRAW	
Idle Current	0.25 A rms (115 V AC); 0.13 A rms (230 V AC); 0.3 A rms (100 V AC)
Maximum Long-Term Continuous Current (>10 sec)	2.8 A rms (115 V AC); 1.4 A rms (230 V AC); 3.2 A rms (100 V AC)
Burst Current (<1 sec) ⁷	3.2 A rms (115 V AC); 1.6 A rms (230 V AC); 3.7 A rms (100 V AC)
Maximum Instantaneous Peak Current	5.0 A pk (115 V AC); 2.5 A pk (230 V AC); 5.8 A pk (100 V AC)
Inrush Current	< 9 A pk (115 V AC and 230 V AC)

SPECIFICATIONS, CONT'D.

RMS NETWORK (OPTIONAL)	
	Equipped with two-conductor twisted-pair network, reporting all operating parameters of amplifiers to system operator's host computer.
PHYSICAL	
Dimensions	W: 14.50 in (368 mm) x H: 22.40 in (569 mm) x D: 14.30 in (363 mm)
Weight	77 lb (34.93 kg)
Enclosure	Premium multi-ply birch, slightly textured black finish
Protective Grille	Powder-coated, hex-stamped steel with black mesh
Rigging	Four ring and stud pan fittings, two on both top and bottom. Working load for each fitting is 420 lb (190.51 kg), 1/5 the cabinet breaking strength (with straight tensile pull); 3/8" or metric M10 nut plates optional

NOTES

- Loudspeaker system predictions for coverage and SPL are available in Meyer Sound's MAPP System Design Tool.
- Recommended maximum operating frequency range. Response depends on loading conditions and room acoustics.
- Free-field, measured with 1/3 octave frequency resolution at 4 m.
- Linear Peak SPL** is measured in free-field at 4 m referred to 1 m. Loudspeaker SPL compression measured with M-noise at the onset of limiting, 2-hour duration, and 50-degree C ambient temperature is < 2 dB.
M-noise is a full bandwidth (10 Hz–22.5 kHz) test signal developed by Meyer Sound to better measure the loudspeaker's music performance. It has a constant instantaneous peak level in octave bands, a crest factor that increases with frequency, and a full bandwidth Peak to RMS ratio of 18 dB. The presence of a greater-than (>) symbol with regard to crest factor indicates it may be higher depending on EQ and boundary loading.
Pink noise is a full bandwidth test signal with Peak to RMS ratio of 12.5 dB.
B-noise is a Meyer Sound test signal used to ensure measurements reflect system behavior when reproducing the most common input spectrum, and to verify there is still headroom over pink noise.
- Two additional 3-pin XLR input module options are available with a polarity reversal switch and an attenuator (0 dB to -18 dB): one looping and one with two inputs for mono summing.
- Peak power based on the maximum unclipped peak voltage the amplifier will produce into the nominal load impedance.
- AC power cabling must be of sufficient gauge so that under burst current rms conditions, cable transmission losses do not cause the loudspeaker's voltage to drop below the specified operating range.

ARCHITECTURAL SPECIFICATIONS

The loudspeaker shall be a self-powered, full-range system. The transducers shall consist of a 12-inch diameter cone driver and a 3-inch diaphragm compression driver on a 100° horizontal x 40° vertical horn.

The loudspeaker system shall incorporate internal processing electronics and a two-channel amplifier. Processing functions shall include equalization, phase correction, signal division and protection for the high- and low-frequency sections. Each amplifier channel shall be class AB/bridged with complementary MOSFET output stages. Burst capability shall be 1000 watts total with nominal impedance of 16 Ω for the high-frequency channel and 2 Ω for the low-frequency channel. Distortion (THD, IM, TIM) shall not exceed 0.02%.

Performance specifications for a typical production unit shall be as follows (free-field, measured with 1/3 octave frequency resolution at 4 m): operating frequency range shall be 60 Hz – 18 kHz; phase response shall be 600 Hz – 16 kHz ±35°; linear peak SPL shall be 130.5 dB with crest factor >14 dB, measured with M-noise, free-field at 4 m referred to 1 m; horizontal coverage shall be 100° and vertical coverage shall be 40°.

The audio input shall be electronically balanced with a 10 kΩ impedance and accept a nominal 0 dBV (1 V rms) signal. Connector shall be XLR 3-pin

female male loop.

The internal power supply shall perform automatic voltage selection, EMI filtering, soft current turn-on and surge suppression. Powering requirements shall be nominal 100, 110 or 230 V AC line current at 50 or 60 Hz. UL and CE operating voltage range shall be 100–240 V AC. Maximum peak current draw during burst shall be 5 A at 115 V AC, 2.5 A at 230 V AC and 5.8 A at 100 V AC. Current inrush during soft turn-on shall not exceed 9 A at 115 V AC. AC power connector shall be PowerCON.

The loudspeaker system shall provide facilities for installing Meyer Sound's optional RMS remote monitoring system.

All loudspeaker components shall be mounted in an acoustically vented trapezoidal enclosure constructed of premium multi-ply birch with a slightly textured black finish. The front protective grille shall be powder-coated, hex-stamped steel with black mesh. Dimensions shall be W: 14.50 in (368 mm) x H: 22.40 in (569 mm) x D: 14.30 in (363 mm). Weight shall be 77 lb (34.93 kg). Rigging points shall be four ring and stud pan fittings, two each on top and bottom, rated at 420 lb (190.51 kg) per fitting, based on a 5:1 safety factor.

The loudspeaker shall be the Meyer Sound UPA-1P.