

# UPQ-2P Narrow Coverage Loudspeaker

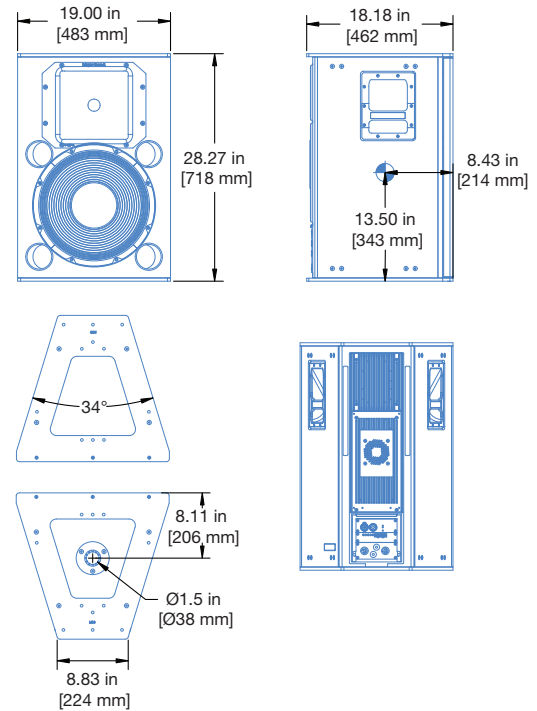

The self-powered, narrow-coverage UPQ-2P loudspeaker offers extremely high power output and low distortion, as well as a focused beamwidth, which make it an ideal solution for small to mid-sized venues, houses of worship, theaters, and nightclubs—as either a stand-alone loudspeaker or as part of an array. The loudspeaker's extended low-frequency headroom delivers a smooth coverage over a wide operating frequency range of 55 Hz to 18 kHz. With its intuitive and versatile QuickFly® rigging options, the UPQ-2P supports touring and rental solutions or fixed applications.

The UPQ-2P is distinguished by its constant-Q horn with a narrow beamwidth (50° by 50°) that yields precise coverage and minimal interaction with walls and neighboring loudspeakers in arrays. The horn's smooth and accurate performance, the result of meticulous research in Meyer Sound's anechoic chamber, exhibits a remarkably consistent beamwidth in both the horizontal and vertical planes across a wide frequency range of 1–18 kHz. In addition, the UPQ-2P horn delivers uniform attenuation for all frequencies outside the specified beamwidth.

Designed and built at Meyer Sound's Berkeley, California factory, the UPQ-2P's drivers include a low frequency 15-inch neodymium magnet cone driver and 4-inch diaphragm compression driver. A proprietary two-channel, class AB/H power amplifier with complementary MOSFET output stages yields a peak power output of 2250 W. Audio input is routed through an electronic crossover,

correction filters, and driver-protection circuitry. Phase-corrected processing, optimized specifically for the UPQ-2P, ensures flat acoustical amplitude and phase response, resulting in an exceptional impulse response and precise imaging. Amplifier channels have sophisticated limiters that are easily monitored with the limit LEDs on the unit's rear panel.

The UPQ-2P's modular amplifier and processing electronics are equipped with Meyer Sound's Intelligent AC™ power supply, which adapts to any power voltage worldwide and provides soft-turn on and transient protection. The UPQ-2P comes standard with XLR input and looping output connectors; an optional version of the loudspeaker includes polarity switching and input attenuation (from 0 dB to -18 dB). The optional RMS™ remote monitoring system module provides comprehensive monitoring of loudspeaker parameters from a host computer running Compass® software.

The UPQ-2P's durable trapezoidal enclosure has a slightly textured black finish. The end plates, which are made of heavy-duty, high-strength, corrosion-resistant 6061-T6 aluminum, include threaded M10 attachment points for basic eyebolt rigging, and a receptacle for third-party pole mounting. QuickFly rigging options include the MPA-UPQ pick-up and array plate, and the MYA-UPQ mounting yoke. Other options include Meyer Sound weather protection, custom cabinets without handles, and custom color finishes for specific cosmetic requirements.

## FEATURES AND BENEFITS

---

- Narrow symmetrical pattern affords precise coverage and arrayability
- Extraordinarily flat amplitude and phase response delivers tonal accuracy and precise imaging
- Integral pole mount and QuickFly mounting options facilitate installation
- Constant-Q horn affords uniform response throughout coverage area
- Exceptional size to power ratio provides application flexibility
- Consistent and predictable performance ensures accurate system design

## APPLICATIONS

---

- Theatrical sound reinforcement
- Houses of worship
- Portable and installed audio-visual systems
- Centerfill and sidefill
- Nightclubs

## ACCESSORIES AND ASSOCIATED PRODUCTS

---

**MPA-UPQ Pick Up and Array Plate:** Allows installation of multiple UPQ-2Ps in arrays

**MYA-UPQ Mounting Yoke:** Cradle-style mounting yoke that suspends a single UPQ-2P loudspeaker and supports a wide range of horizontal and vertical adjustment.

**Galileo GALAXY Network Platform:** The Galileo GALAXY Network Platform provides state-of-the-art audio control technology for loudspeaker systems with multiple zones. With immaculate sonic performance, it provides a powerful tool set for corrective room equalization and creative fine-tuning for a full range of applications.

**MDM-832 Distribution Module:** MDM-832 units conveniently power UPQ-2P arrays, routing up to eight channels of AC power, balanced audio and RMS signals to the loudspeakers.

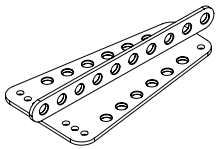

**MPA-UPQ Pick Up and Array Plate**

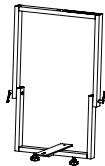

**MYA-UPQ Mounting Yoke**

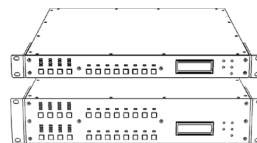

**GALAXY Network Platform**

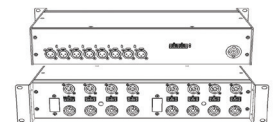

**MDM-832 Distribution Module**

## SPECIFICATIONS

ACOUSTICAL <sup>1</sup>	
Operating Frequency Range <sup>2</sup>	55 Hz – 18 kHz
Frequency Response <sup>3</sup>	60 Hz – 16 kHz $\pm$ 4 dB
Phase Response	490 Hz – 16 kHz $\pm$ 45°
Linear Peak SPL <sup>4</sup>	<b>135 dB with 18 dB crest factor, (M-noise)</b> , 133.5 dB (Pink noise), 135 dB (B-noise)
COVERAGE	
	50° horizontal x 50° vertical (-6 dB) 60° horizontal x 60° vertical (-10 dB)
TRANSDUCERS	
Low Frequency	One high-power 15-inch cone driver with neodymium magnet; 2 $\Omega$ nominal impedance
High Frequency	One 4-inch diaphragm compression driver; 8 $\Omega$ nominal impedance
AUDIO INPUT	
Type	Differential, electronically balanced
Maximum Common Mode Range	$\pm$ 15 V DC, clamped to earth for voltage transient protection
Connectors	XLR 3-pin female input with male loop output; optional 5-pin connectors to accommodate both balanced audio and RMS signals
Input Impedance	10 k $\Omega$ differential between pins 2 and 3
Wiring <sup>5</sup>	Pin 1: Chassis/earth through 220 k $\Omega$ , 1000 pF, 15 V clamp network to provide virtual ground lift at audio frequencies Pin 2: Signal + Pin 3: Signal—(optional polarity reversal switch) Case: Earth ground and chassis
Nominal Input Sensitivity	0 dBV (1.0 V rms) continuous is typically the onset of limiting for noise and music
Input Level	Audio source must be capable of producing of +20 dBV (10 V rms) into 600 $\Omega$ to produce the maximum peak SPL over the operating bandwidth of the loudspeaker.
AMPLIFIER	
Type	Two-channel complementary MOSFET output stages (class AB/H)
Total Output Power <sup>6</sup>	2250 W peak
THD, IM, TIM	< 0.02%
Cooling <sup>7</sup>	Convection at low to mid audio levels; fan-assisted only at high audio levels
AC POWER	
Connector	PowerCON 20 input with loop output
Automatic Voltage Selection	Two ranges, each with high-low voltage tap (uninterrupted)
Safety Rated Voltage Range	95–125 V AC; 208–235 V AC, 50–60 Hz
Turn-on and Turn-off Points	85–134 V AC; 165–264 V AC
CURRENT DRAW	
Idle Current	0.50 A rms (115 V AC); 0.28 A rms (230 V AC); 0.56 A rms (100 V AC)
Maximum Long-Term Continuous Current (>10 sec)	3.9 A rms (115 V AC); 2.0 A rms (230 V AC); 4.4 A rms (100 V AC)
Burst Current (<1 sec) <sup>8</sup>	7.0 A rms (115 V AC); 3.9 A rms (230 V AC); 8.2 A rms (100 V AC)
Maximum Instantaneous Peak Current	18.0 A peak (115 V AC); 10.5 A peak (230 V AC); 20.0 A peak (100 V AC)
Inrush Current	6.0 A peak (115 V AC); 8.4 A peak (230 V AC); 7.1 A peak (100 V AC)
RMS NETWORK (OPTIONAL)	
	Equipped with two-conductor twisted-pair network, reporting all operating parameters of amplifiers to system operator's host computer.

## SPECIFICATIONS, CONT'D.

PHYSICAL	
Dimensions	W: 19.00 in (483 mm) x H: 28.27 in (718 mm) x D: 18.18 in (462 mm)
Weight	108 lb (49 kg)
Enclosure	Premium multi-ply birch with slightly textured black finish
Protective Grille	Powder-coated, hex-stamped steel with black mesh
Rigging	Aluminum end plates on top and bottom with metric M10 threaded points; integral 1.5-inch (38 mm) pole mount receptacle on bottom

## NOTES

- Loudspeaker system predictions for coverage and SPL are available in Meyer Sound's MAPP System Design Tool.
- Recommended maximum operating frequency range. Response depends on loading conditions and room acoustics.
- Free-field, measured with 1/3 octave frequency resolution at 4 m.
- Linear Peak SPL** is measured in free-field at 4 m referred to 1 m. Loudspeaker SPL compression measured with M-noise at the onset of limiting, 2-hour duration, and 50 °C ambient temperature is < 2 dB.  
**M-noise** is a full bandwidth (10 Hz–22.5 kHz) test signal developed by Meyer Sound to better measure the loudspeaker's music performance. It has a constant instantaneous peak level in octave bands, a crest factor that increases with frequency, and a full bandwidth Peak to RMS ratio of 18 dB.  
**Pinknoise** is a full bandwidth test signal with Peak to RMS ratio of 12.5 dB.  
**B-noise** is a Meyer Sound test signal used to ensure measurements reflect system behavior when reproducing the most common input spectrum, and to verify there is still headroom over pink noise.
- An additional input module option is available with a polarity reversal switch and an attenuator (0 dB to -18 dB).
- Peak power based on the maximum unclipped peak voltage the amplifier will produce into the nominal load impedance.
- The fan is controlled by audio level. It remains off at turn-on and at low to mid audio levels. Operating only at high audio levels makes it virtually inaudible.
- AC power cabling must be of sufficient gauge so that under burst current rms conditions, cable transmission losses do not cause the loudspeaker's voltage to drop below the specified operating range.

## ARCHITECTURAL SPECIFICATIONS

The loudspeaker shall be a self-powered, full-range system; the transducers shall be a 15-inch diameter cone driver and a 4-inch diaphragm compression driver on an 50° horizontal x 50° vertical horn. The loudspeaker system shall incorporate internal processing electronics and a two-channel amplifier, one channel for each driver. Processing functions shall include equalization, phase correction, signal division, and protection for the high- and low-frequency sections.

Each amplifier channel shall be class AB/H with complementary MOSFET output stages. Peak power shall be 2250 W. Distortion (THD, IM, TIM) shall not exceed 0.02%.

Performance specifications for a typical production unit shall be as follows: operating frequency range shall be 55 Hz–18 kHz (free-field, measured with 1/3-octave resolution at 4 m); phase response shall be from 490 Hz–16 kHz  $\pm 45^\circ$ ; linear peak SPL shall be 135 dB with 18 dB crest factor, measured with M-noise, free-field at 4 m referred to 1 m; coverage shall be 50° horizontal x 50° vertical horn at the -6 dB points and 60° horizontal x 60° vertical horn at the -10 dB points.

The audio input shall be electronically balanced with a 10 k $\Omega$  impedance and accept a nominal 0 dBV (1 V rms) signal. Connector shall be XLR 3-pin female input with male loop output. An additional input module shall be offered with an attenuator and polarity reversal switch including one with loop-through output.

The internal power supply shall perform automatic voltage selection, EMI filtering, soft current turn-on, and surge suppression. Power requirements shall be nominal 100, 110, or 230 V AC line at 50 or 60 Hz. UL and CE operating voltage range shall be 100–240 V AC. Maximum peak current draw during burst shall be 7.0 A at 115 V AC, 3.9 A at 230 V AC, and 8.2 A at 100 V AC. Current inrush during soft turn-on shall not exceed 6.0 A at 115 V AC or 8.4 A at 230 V AC. AC power connectors shall be a PowerCon with looping capabilities.

The loudspeaker system shall provide facilities for installing Meyer Sound's optional RMS remote monitoring system.

All components shall be mounted in an acoustically vented trapezoidal enclosure constructed of premium multi-ply birch with a slightly textured black finish. The enclosure shall include an integral 1.5-inch (38 mm) diameter pole mount receptacle and versatile rigging end plates made of high-strength, 6061-T6 aluminum with threaded M10 metric holes for basic eyebolt rigging and shall also accommodate Meyer Sound proprietary rigging hardware. The front protective grille shall be powder-coated, hex-stamped steel with black mesh screen. Dimensions shall be W: 19.00 in (483 mm) x H: 28.27 in (718 mm) x D: 18.18 in (462 mm). Weight shall be 108 lb (49 kg).

The loudspeaker shall be the Meyer Sound UPQ-2P.

